

Description

The NuVent MR Series fan-lights offer exceptionally quiet performance in a sturdy galvanized steel housing plus a bright ceiling light. All MR Series fan-lights feature a round grille with curved vents for contemporary style. An attractive option for bathroom and general ventilation applications.

Features

Grille/Light Assembly

- Attractive square styling with soft curved vents and removable lens.
- Textured, white polymeric.
- Mounts directly to housing with #10 Philips hex screw (included).

Housing

- Heavy 22-gauge galvanized steel construction.
- Plastic discharge collar with backdraft damper for easy attachment to 4" diameter duct.
- Mounts with side mounting tabs or hanger bars (included).
- Top and side electrical knockouts for easy access.
- Large removable wiring compartment.

Blower

- Removable blower with easy slide-in mounting
- Balanced polymeric, forward curved blower wheel.
- Plug in motor rated for 120 volts 60 Hz operation.

Light

- Bright 100 watt incandescent light (bulb not included).

Other

- Permanently lubricated, ball bearing shaded pole motor.
- This product is approved for use over tub/shower enclosures when installed in a GFI protected branch circuit.
- Also available in MS Series with square grille.

Performance

- Air Delivery – 70 CFM @ .1" w.g. s.p.
- Sound Level - 4.5 sones
- Volts – 120
- Hertz – 60
- Amps – 1.88
- Watts – 49.4 (fan only)
- Duct – 4" round
- Lamp – 100 watt max. A-19



The Home Ventilating Institute has tested and certified the airflow performance (CFM) and sound levels (sones) of this product.

General

This product has been evaluated by Underwriters Laboratories and conforms to both UL and CSA safety standards.



Specifications

NuVent fan-light combination NXMR70L. The fan-light shall be constructed with a galvanized steel housing featuring side tab or hanger bar mounting and 4" diameter discharge collar. The blower unit shall be removable with a permanently lubricated, ball bearing, plug-in motor. Air delivery and sound levels shall be certified by HVI at the levels listed for this model. All units shall be UL listed.

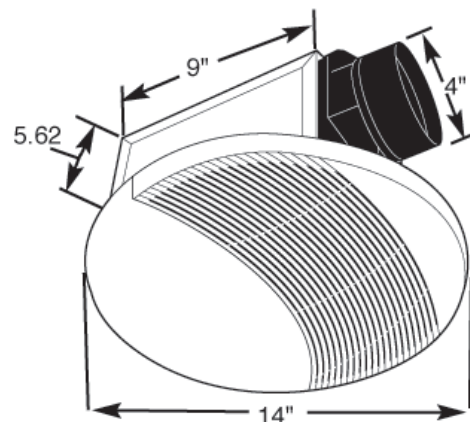

**NuVent Product Performance
Model NXMR70L**

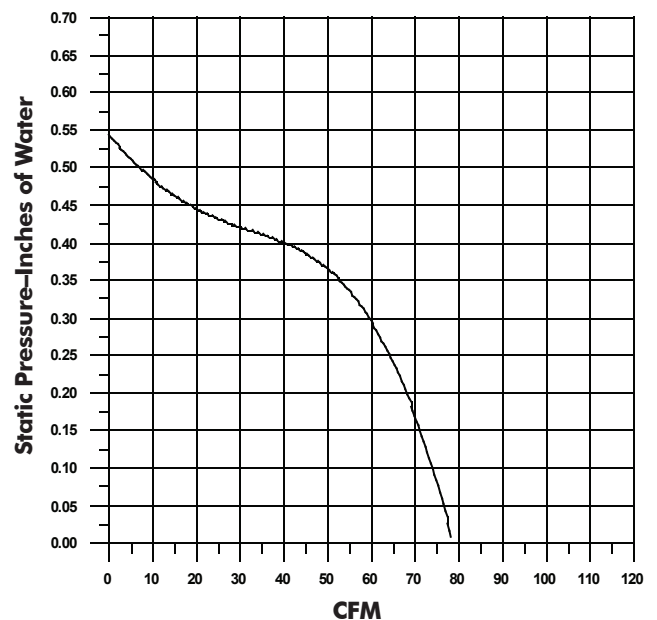

SPECIFICATION			PROJECT:
Reference	Quantity	Comments	Location:
			Architect:
			Engineer:
			Contractor:
			Submitted by:
			Date: